

## Top of Car Handrail



Part No. 18-400



Part No. 18-400-R

This handrail kit shares all the same great features of the Wurtec 18-400 series top of car handrail, but it is octagonal making it an easy fit for round car tops ranging from 74" to 120" in diameter.

### Description

The Wurtec top of car handrail is a fully adjustable (telescopic tubing) design that will adapt to existing cab configurations and new installations. The kit comes complete with all necessary assembly hardware and kick plates. All material is galvanized for corrosion prevention.

### Key Features

- Fully adjustable (telescopic) design that will adapt to existing cab configurations & new installations
- Easy/Fast to install
- Ship via UPS
- Made from galvanized 16 gauge tubing
- Assembly hardware provided
- Several models available, suited for front only and front and rear opening car configurations.
- Designed to be mounted to the edge of the elevator canopy
- Kick plate provided for field adaptation
- Custom sizes available upon request
- Designed to comply with latest code revisions: ASME A17.1a-2002, 2.14.1.7 and 2.10.2

### Specifications

Part No.	Configuration	size (min. - max.)		Weight (lbs.)
		width (in.)	depth (in.)	
18-400	FRONT OPENING	66" - 96"	46" - 70"	116 LBS.
18-400-R	FRONT OPENING	-	-	143 LBS
18-410	FRONT OPENING	46" - 70"	66" - 110"	139 LBS
18-420	FRONT & REAR OPENING	UP TO 72"	66" - 110"	118 LBS
18-430	FRONT & REAR OPENING	UP TO 96"	46" - 70"	86 LBS
18-440	FRONT OPENING	66" - 96"	66" - 96"	134 LBS
18-450	FRONT OPENING	66" - 96"	66" - 110"	143 LBS

## Top of Car Handrail

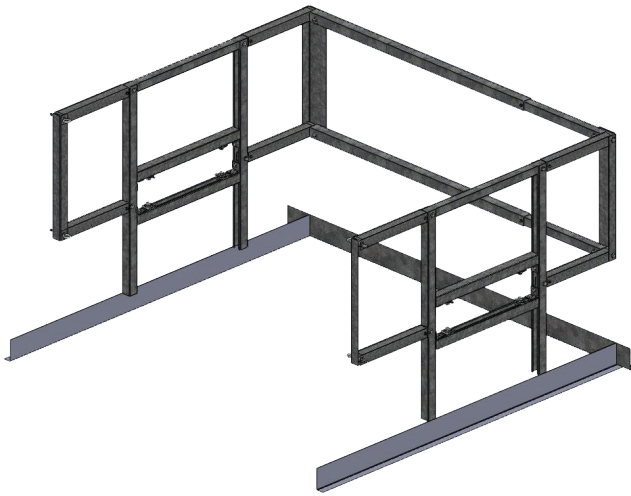

### Product Description

The crosshead mounted top of car handrail builds on the design of the top of car handrail by allowing for attachment to the crosshead, which can help reduce noise in the car. This design still offers telescoping handrails and all material is galvanized to prevent corrosion. An aluminum version is available to allow for weight saving – often critical in modernizations. A collapsible version is available for low overheads that will allow the handrail to be collapsed to 22 7/8" while the car is running, and extended for use when working on top of the car.

### Key Features

- Fully adjustable (telescopic) design that will adapt to existing cab configurations & new installations
- Adjustable rails to set at code required heights of 21" and 42" (18-460)
- Easy/Fast to install
- Ship via UPS
- Made from galvanized 16 gauge tubing
- Assembly hardware provided
- Designed to be mounted to the Crosshead
- Kick plate provided for field adaptation
- Aluminum and custom sizes available upon request
- Designed to comply with latest code revisions: ASME A17.1a-2002, 2.14.1.7 and 2.10.2
- 3 Piece partial assembly option available, ask for details.
- Limit Switch included on Collapsible Handrail

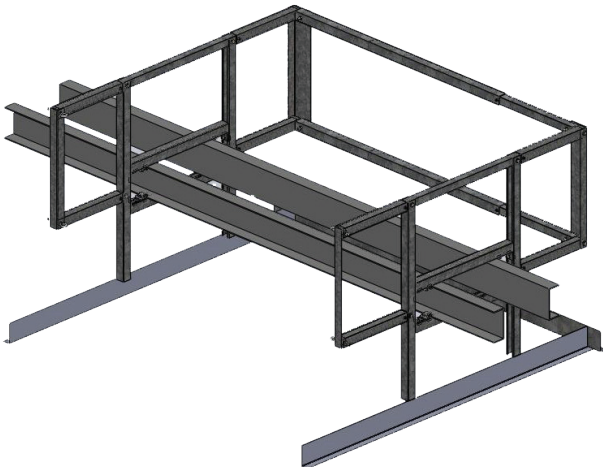

### Specifications

Part No.	Configuration	Size (min. - max.)		Weight (lbs.)
		Width (in.)	depth (in.)	
18-460	FRONT OPENING	56" - 96"	60" -75"	127 (58 KGS)
18-465	FRONT OPENING	56" - 96"	75" - 110"	150 (68 KGS)
18-460-C	FRONT OPENING COLLAPSIBLE	56" - 96"	60" - 75"	128 (58 KGS)
18-465-C	FRONT OPENING COLLAPSIBLE	56" - 96"	75" - 110"	149 (68 KGS)